



MULTI-PARAMETER - MULTI-GAS MASS FLOW METER

DPM



Design Features

- Multi-Parameter functionality: Mass Flow, Volumetric Flow, Gas Pressure and Temperature.
- Multi-Gas functionality: support for 90 different gases and gas mixes.
- “User Defined Mixture” functionality allows to create and store up to 20 custom gas mixes with up to 5 different gases each.
- Quick (< 20ms) response time.
- Standard accuracy \pm (0.5% RD + 0.2% FS).
- 200 to 1 turndown ratio.
- Two programmable mass flow rate totalizers.
- High, Low or In Range Alarms with preset action delay for Mass Flow, Temperature and Pressure.
- User programmable mass flow rate Pulse Output (via SSR).
- Extensive Self Diagnostics with status LED or OLED indication.
- All 3 user selectable analog output interfaces are standard: 0-5Vdc, 0-10Vdc, 4-20mA.
- Two user selectable digital communication interfaces (RS-232 and RS-485) are standard.
- Optional Modbus RTU network interface with isolated RS485 transceiver.
- User programmable solid state relay with latch option.
- Universal 9-26 Vdc power supply input.
- Local high contrast OLED (optional) graphic display with joystick control.
- Free, easy-to-use configuration and calibration software (RS-232/RS-485).

General Description

Aalborg Instruments' DPM series digital multi-parameter mass flow meter provides accurate measurements of mass flow rate, volumetric flow rate, pressure and temperature of process gases. It can be used in a variety of industries: scientific and analytical applications, bioreactors and surface depositions, gas sampling, manufacturing and metrology activities.

DPM series digital mass flow meters incorporate multi-parameter multi-gas functionality which allows users on site to select up to 30 different gases locally via optional OLED/Joystick interface, remotely via the RS232/RS485 interface or optional Modbus RTU interface. Standard accuracy is \pm (0.5% RDG + 0.2% FS). Turn down ratio is 200:1. Response time is 10-20 ms.

DPM flow meters support various functions including: two programmable flow totalizers, low, high or range flow, temperature and pressure alarms, automatic zero adjustment (activated via local or communication interface), programmable SSR relay, programmable 0-5 Vdc, 0-10 Vdc or 4-20 mA analog outputs, user-programmable pulse output (via SSR), and extensive self-diagnostics functionality.

Significant savings become apparent when comparing the cost of a single DPM meter embodying these features, with that of acquiring and installing multiple, application-specific devices.

Principles of Operation

Operation of DPM flow meters is based on the measurement of the differential pressure across specially designed restrictor flow elements. The restrictor flow element is designed to establish laminar flow across the entire range of the instrument's operation from 0 to 133% of full scale range.

A high accuracy and high resolution **differential** pressure sensor is utilized to measure pressure drop across a laminar flow channel, which is linearly proportional to volumetric flow rate. To convert volumetric flow into mass flow, high accuracy and high resolution **absolute** pressure and temperature sensors are utilized. Based on data from the sensors and gas properties from the built-in data base of the instrument, the microcontroller calculates volumetric and mass flow, which along with pressure and temperature parameters are available on the instrument display or via digital interfaces. In addition, the mass flow reading is accessible via the instrument analog interface which can be set by user to 0-5, 0-10 Vdc or 4-20mA mode.

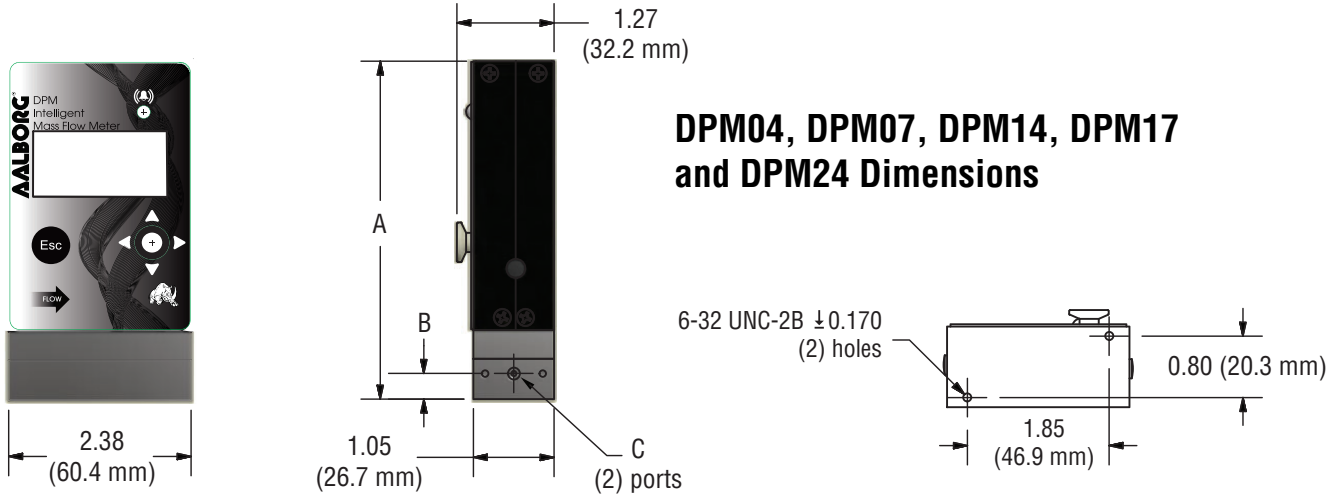

	A	B	C
DPM04 / DPM07	4.40 (111.8 mm)	0.34 (8.5 mm)	10-32 UNF-2B
DPM14 / DPM17	4.58 (116.2 mm)	0.35 (8.9 mm)	1/8-27 NPT
DPM24	5.0 (127.0 mm)	0.35 (8.9 mm)	1/4-18 NPT

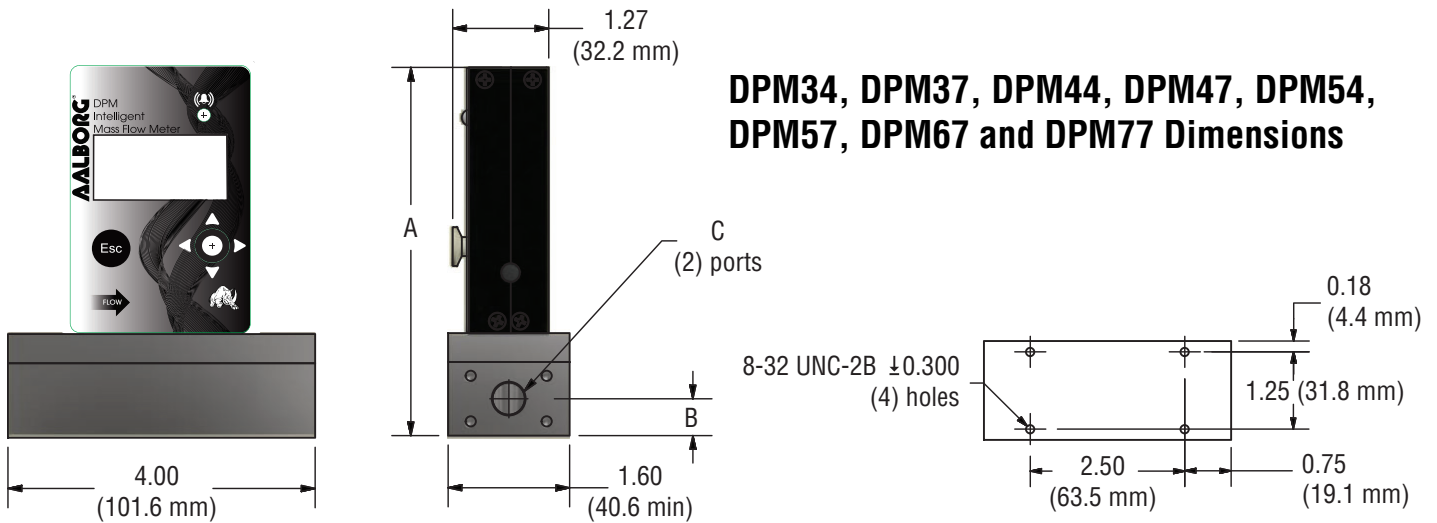

	A	B	C
DPM34 / DPM37	4.85 (123.2 mm)	0.49 (12.3 mm)	1/4"-18 NPT
DPM44 / DPM47	4.85 (123.2 mm)	0.49 (12.3 mm)	1/4"-18 NPT
DPM54 / DPM57	5.48 (139.1 mm)	0.80 (20.3 mm)	1/2"-14 NPT
DPM67	5.48 (139.1 mm)	0.80 (20.3 mm)	3/4"-14 NPT
DPM77	5.48 (139.1 mm)	0.80 (20.3 mm)	3/4"-14 NPT

TABLE 19 - DPM FLOW RANGES

MODEL NO.	FULL SCALE MASS FLOW RATE	PRESSURE DROP AT FULL SCALE FLOW (PSID)	PROCESS CONNECTION
STANDARD PRESSURE DROP [AIR]			
DPM07	0.5 to 50 smL/min	1.0	10-32 Female Thread
DPM17	51 smL/min to 20 sL/min	1.0	1/8" NPT Female
DPM37	21 sL/min to 50 sL/min	2.0	1/4" NPT Female
DPM47	51 sL/min to 100 sL/min	2.5	1/4" NPT Female
DPM57	101 sL/min to 250 sL/min	5.5	1/2" NPT Female
DPM67	251 sL/min 500 sL/min	5.5	3/4" NPT Female
DPM77	501 sL/min to 1000 sL/min	7.0	3/4" NPT Female
DPM (BREEZE™) LOW PRESSURE DROP [AIR]			
DPM04	0.5 smL/min to 20 smL/min	0.06	10-32 Female Thread
DPM14	21 smL/min to 2 sL/min	0.07	1/8" NPT Female
DPM24	2.1 sL/min to 10 sL/min	0.085	1/4" NPT Female
DPM34	10.1 sL/min to 20 sL/min	0.3	1/4" NPT Female
DPM44	20.1 sL/min to 40 sL/min	0.15	1/2" NPT Female
DPM54	40.1 sL/min to 100 sL/min	0.25	3/4" NPT Female

TABLE 20 - DPM ACCESSORY'S

FITTINGS		
MODEL NO.	FITTING CODE	DESCRIPTION
DPM07 / 04	F1C5	10-32 Thread, 1/8" Tubing, Compression, 316 ss.
DPM07 / 04	F2C5	10-32 Thread, 1/8" Tubing, Compression, Nickel Plated Brass.
DPM17 / 14	F2C2	1/8" NPT Thread, 1/8" tubing, Compression, 316 ss.
DPM17 / 14	F2C4	1/8" NPT Thread, 1/4" tubing, Compression, 316 ss.
DPM37 / 34	F4C4	1/4" NPT Thread, 1/4" tubing, Compression, 316 ss.
DPM24 / 34 / 47	F4C6	1/4" NPT Thread, 3/8" tubing, Compression, 316 ss.
DPM44 / 57	F8C6	1/2" NPT Thread, 3/8" tubing, Compression, 316 ss.
DPM54 / 67	1210-1-12-316	3/4" NPT Thread 3/4" tubing, Compression, 300 series ss.
DPM54 / 77	1210-1-12-316	3/4" NPT Thread 3/4" tubing, Compression, 300 series ss.
POWER SUPPLIES		
PS-GFM-110NA-2	Power Supply, 110 V / 12 Vdc / North America.	
PS-GFM-110NA-4	Power Supply, 110 V / 24 Vdc / North America.	
PS-GFM-230EU-2	Power Supply, 220 V / 12 Vdc / Europe.	
PS-GFM-230EU-4	Power Supply, 220 V / 24Vdc / Europe.	
PS-GFM-240UK-2	Power Supply 240 V / 12 Vdc / United Kingdom.	
CABLES		
CBL-A232	Communication Cable for DPM with RS-232 Interface 1.5 FT 3.5mm stereo audio con. with 3-wire to 9 pins female D-connector (included with each DPM).	
CBL-A485	Communication Cable for DPM with RS-485 Interface 3 FT 3.5mm stereo audio con. with 3-wire to stripped ends.	
CBL-8MINIDIN-3	Shielded cable 8 pins MinDin with stripped ends 3 feet long.	
CBL-8MINIDIN-12	Shielded cable 8 pins MinDin with stripped ends 12 feet long.	
COMMUNICATION PORT ACCESSORIES		
USB-RS232	USB to RS232 converter.	
USB-RS485	USB to RS485 converter.	
MODBUS INTERFACE ACCESSORIES		
ECS803-1	RJ45 shielded Y-adapter (Passive TAP).	
TDG1026-8C	RJ45 Modular Coupler.	
MOD27T	RJ45 Line Terminator (100 Ohm 0.25 W).	
JMOD4S-1	RJ45 Splitter fully shielded (5xRJ45, 1 input 4 outputs).	
TRD815BL-2	Category 5E Patch Twisted Pair Cable, RJ45 / RJ45, Blue 2.0 feet.	
TRD815BL-10	Category 5E Patch Twisted Pair Cable, RJ45 / RJ45, Blue 10.0 feet.	
TRD815BL-25	Category 5E Patch Twisted Pair Cable, RJ45 / RJ45, Blue 25.0 feet.	

TABLE 21 - DPM SPECIFICATIONS

FLOW MEDIUM	Please note that DPM Mass Flow Meters are designed to work only with clean, non-corrosive gases. Never try to measure flow rates of liquids with any DPM.	
CALIBRATIONS	Perform at standard conditions [14.7 psia (101.4 kPa) and 70 °F (21.1 °C)] unless otherwise requested or stated.	
ENVIRONMENTAL (PER IEC 664):	Installation Level II; Pollution Degree II.	
FLOW ACCURACY (INCLUDING LINEARITY):	±(0.5% RD + 0.2% FS) at calibration temperature and pressure.	
REPEATABILITY:	±0.15% of full scale.	
FLOW TEMPERATURE COEFFICIENT:	0.05% of full scale/ °C or better.	
FLOW PRESSURE COEFFICIENT:	0.01% of full scale/psi (6.895 kPa) or better.	
FLOW RESPONSE TIME:	Default 10 ms (adjustable by user).	
INSTRUMENT WARM-UP TIME:	< 5 seconds.	
MAXIMUM MEASURABLE FLOW RANGE:	133% Full Scale.	
OPERATING RANGE / TURNDOWN RATIO:	0.5% to 100% Full Scale / 200:1.	
MASS REFERENCE CONDITIONS (STP):	70 °F & 14.696 PSIA (other available on request).	
MAXIMUM INTERNAL GAS PRESSURE (STATIC):	DPM07 /17 /37 /47 /57 /67 /77	120 PSIG
	DPM04 /14 /24 /34 /44 /54	50 PSIG
MAXIMUM INSTANTANEOUS DIFFERENTIAL PRESSURE ACROSS INLET AND OUTLET:	DPM07 /17 /37 /47 /57 /67 /77	12 PSID
	DPM04 /14 /24 /34 /44 /54	9.75 PSID
PROOF PRESSURE:	DPM07 /17 /37 /47 /57 /67 /77	145 PSIG
	DPM04 /14 /24 /34 /44 /54	50 PSIG
OPERATING TEMPERATURE:	-10 to +60 °C (14 to 140 °F).	
MOUNTING ATTITUDE SENSITIVITY:	None.	
RELATIVE GAS HUMIDITY RANGE:	0 to 100% (Non -Condensing).	
INGRESS PROTECTION:	IP40.	
OUTPUT SIGNALS:	Linear 0-5 Vdc (3000 ohms min. load impedance);	
	Linear 0-10 Vdc (5000 ohms min. load impedance); with power supply >= 12Vdc.	
	Linear 4-20 mA (550 ohms maximum loop resistance) with power supply >= 12Vdc.	
	Maximum noise 10mV peak to peak (for 0-5/0-10 Vdc output).	
TRANSDUCER INPUT POWER:	9 to 26 Vdc, 150 mV maximum peak to peak output noise. Power consumption: 100 mA maximum. Circuit board has built-in polarity reversal protection, 300mA resettable fuse provide power input protection.	
DIGITAL OUTPUT SIGNALS:	Standard RS-232 or RS-485 (user selectable). Optional Modbus over isolated RS-485 transceiver.	
** MATERIALS FLUID CONTACT:	316 stainless steel, 416 stainless steel, high temperature polyamide, alumina ceramic, epoxy, silicone, glass, gold. Viton® O-rings.	

** The selection of materials of construction, is the responsibility of the customer. The company accepts no liability.

DPM	MODEL							
MAX FLOW (Air)								
Standard Pressure Drop	07	0.5 sml/min to 50 sml/min						
	17	51 sml/min to 20 sL/min						
	37	21 sL/min to 50 sL/min						
	47	51 sL/min to 100 sL/min						
	57	250 sL/min						
	67	500 sL/min						
	77	1000 sL/min						
Breeze™ Low Pressure Drop	04	0.5 smL/min to 20 smL/min						
	14	21 smL/min to 2 sL/min						
	24	2.1 sL/min to 10 sL/min						
	34	10.1 sL/min to 20 sL/min						
	44	20.1 sL/min to 40 sL/min						
	54	40.1 sL/min to 100 sL/min						
MATERIAL								
S	Stainless Steel							
SEALS								
V	Viton®							
CONNECTIONS								
0	Not Included (Optional Accessory)							
OLED READOUT								
N	NO Display							
L	OLED Readout							
POWER								
6	Universal 9 to 26 Vdc							
OUTPUT SIGNAL								
A	0-5 Vdc							
B	4-20 mA							
M	0-10 Vdc							
DIGITAL INTERFACE								
2	RS232							
5	RS485							
3	RS232 with Modbus							
4	RS485 with Modbus							
DPM	17	S	V	0	L	6	A	3

EXAMPLE: DPM17S-VOL6-A3

SPECIFY: FLOW RANGE, GAS and PRESSURE *n.a. = not applicable.

DPM17, 316 stainless steel, Viton® seals, with OLED readout 9-26 Vdc, 0-5 Vdc output signal, RS 232 with Modbus