

Model GFC thermal Mass Flow Controllers are designed to indicate and control set flow rates of gases.

The GFC combines the characteristics and accuracy of conventional mass flow devices into a unique compact design at low costs previously unattainable.

Each of these controllers incorporates an advanced straight tube sensor in conjunction with flow passage elements constructed of aluminum and brass for non-corrosive gases or 316 stainless steel for corrosive applications. Zero and span adjustments are accessible from the outside of transmitters.

### Principles of Operation

Metered gases are divided into two laminar flow paths, one through the primary flow conduit, and the other through a capillary sensor tube. Both flow conduits are designed to ensure laminar flows and therefore the ratio of their flow rates is constant.

Two precision temperature sensing windings on the sensor tube are heated, and when flow takes place, gas carries heat from the upstream to the downstream windings. The resultant temperature differential is proportional to the change in resistance of the sensor windings.

A Wheatstone bridge design is used to monitor the temperature dependent resistance gradient on the sensor windings which is linearly proportional to the instantaneous rate of flow.

Output signals of 0 to 5Vdc and 4 to 20mA are generated indicating mass molecular based flow rates of the metered gas. The combined gas streams flow through a proportionating electromagnetic valve with an appropriately selected orifice. The closed loop control circuit continuously monitors the mass flow output and maintains it at the set flow rate.

Flow rates are unaffected by temperature and pressure variations within stated limitations.

### Design Features

- Rigid metallic construction.
- Maximum pressure of 1000 psig (70 bars).
- Leak integrity  $1 \times 10^{-9}$  smL/sec of helium.
- NIST traceable certification.
- Built-in tiltable LCD readout.
- Local or remote setpoint control.
- 0-5 Vdc and 4-20 mA signals.
- Circuit protection.
- TIO Totalizer option.

### General Description

Compact, self-contained GFC mass flow controllers are designed to indicate and control flow rates of gases. The rugged design coupled with instrumentation grade accuracy provides versatile and economical means of flow control. Aluminum or stainless steel models with readout options of either engineering units (standard) or 0 to 100 percent displays are available. The built-in electromagnetic valve allows the flow to be set to any desired flow rate within the range of the particular model.



Setpoints are controlled either locally or remotely. The valve is normally closed as a safety feature to ensure that gas flow is shut off in case of a power outage. The LCD readout built into the top of the transducer is tiltable over 90 degrees to provide optimal reading comfort. It is connected to the transducer by a standard modular plug, and is readily removable for remote reading installations. Transducers without LCD readout are offered for OEM applications. GFC mass flow controllers are available with flow ranges from 10 mL/min to 1000 L/min N<sub>2</sub>. Gases are connected by means of 1/4", 3/8", or optional 1/8" compression fittings and 3/4" FNPT fittings. Optional fittings are available. These controllers may be used as bench top units or mounted by means of screws in the base. Transducer power supply ports are fuse and polarity protected.

## Leak Integrity

1 x 10<sup>-9</sup> mL/sec of helium maximum to the outside environment.

TABLE 22 - SPECIFICATIONS

ACCURACY:	ACCURACY %FS			OPTIONAL ENHANCED ACCURACY %FS				
	MODEL:	GFC 17, 37, 47	GFC 57, 67, 77		MODEL:	GFC 57, 67, 77		
	FLOW RANGE:	0-100%	20-100%	0-20%	FLOW RANGE:	20-100%	0-20%	
	ACCURACY:	±1.0%	±1.5%	±3%	ACCURACY:	±1%	±1.0%	REF DATA with ±1%
<b>CALIBRATIONS:</b>	Performed at standard conditions [14.7 psia (101.4 kPa) and 70 °F (21.1 °C)] unless otherwise requested.							
<b>REPEATABILITY:</b>	±0.5% of full scale.							
<b>RESPONSE TIME:</b>	<b>GFC17:</b>	300ms time constant; approximately 1 second to within ±2% of set flow rate for 25% to 100% of full scale flow.						
	<b>GFC 37/47:</b>	600ms time constant; approximately 2 seconds to within ±2% of set flow rate for 25% to 100% of full scale flow.						
	<b>GFC 57/67/77:</b>	1800ms time constant; approximately 5 seconds to within ± 2% of set flow rate for 25% to 100% of full scale flow.						
<b>TEMPERATURE COEFFICIENT:</b>	0.15% of full scale / °C.							
<b>PRESSURE COEFFICIENT:</b>	0.01% of full scale / psi (0.07 bar).							
<b>PRESSURE DROP:</b>	See Table 24.							
<b>OPTIMUM GAS PRESSURE:</b>	25 psig (1.73 bars).							
<b>MAX. GAS PRESSURE:</b>	1000 psig (70 bars) maximum GFC 17, 37, 47. 500 psig (34.5 bars) GFC 57, 67, 77.							
<b>TURN DOWN RATIO:</b>	40:1.							
<b>MAX. DIFF. PRESSURE:</b>	50 psi for GFC 17/37/57/67 and 77 (3.4 bars), 40 psi for 47 (2.7 bars).							
<b>GAS AND AMBIENT TEMP:</b>	32 °F to 122 °F (0 °C to 50 °C). 14 °F to 122 °F (-10 °C to 50 °C) - Dry gases only.							
<b>**MATERIALS IN FLUID CONTACT:</b>	<p>a. Aluminum models GFC Series: anodized aluminum, 316 stainless steel, brass and Viton® O-rings.</p> <p>b. Stainless steel models GFC17S, 37S, 47S, 57S, 67S and 77S: 316 stainless steel and Viton® O-rings. Optional O-rings: Buna® EPR and Kalrez® .</p>							
<b>ATTITUDE SENSITIVITY:</b>	No greater than +15 degree rotation from horizontal to vertical; standard calibration is in horizontal position.							
<b>OUTPUT SIGNALS:</b>	Linear 0-5 Vdc. (1000 ohms min. load impedance); 4-20 mA (0-500 ohms loop resistance) Max noise ±20mV.							
<b>COMMAND SIGNALS:</b>	Analog 0-5 Vdc or 4-20 mA for remote set point mode; NPN compatible purge /valve off.							
<b>CONNECTIONS:</b>	<b>GFC 17:</b>	1/4" compression fittings. Optional: 6mm, 3/8" and 1/8" compression fittings or 1/4" VCR® .						
	<b>GFC 37:</b>	1/4" compression fittings. Optional: 6mm and 3/8" compression fittings or 1/4" VCR® .						
	<b>GFC 47:</b>	3/8" compression fittings.						
	<b>GFC 57:</b>	3/8" compression fittings.						
	<b>GFC 67:</b>	1/2" compression fittings.						
	<b>GFC 77:</b>	3/4" FNPT fittings. Optional: 3/4" compression fittings.						
<b>LEAK INTEGRITY:</b>	1 x 10 <sup>-9</sup> smL/sec of helium maximum to the outside environment.							
<b>TRANSDUCER INPUT POWER:</b>	<p><b>GFC 17, 37 and 47:</b> Universal +12 Vdc to 26 Vdc, 650 mA maximum.</p> <p><b>GFC 57, 67 and 77:</b> +12 Vdc, 800 mA; +24 Vdc, 650 mA optional.</p>							
<b>CIRCUIT PROTECTION:</b>	Circuit boards have built-in polarity reversal protection. Resettable fuses provide power input protection.							
<b>DISPLAY:</b>	3-1/2 digit LCD, 0.5" high characters.							
<b>CE COMPLIANT:</b>	EN 55011 class 1, class B; EN50082-1.							

\*\*The selection of materials of construction, is the responsibility of the customer. The company accepts no liability.

**TABLE 23 - FLOW RANGES FOR GFC**

GFC 17 LOW FLOW MASS FLOW CONTROLLER	
CODE	mL / min [N <sub>2</sub> ]
01	0 to 10
02	0 to 20
03	0 to 50
04	0 to 100
05	0 to 200
06	0 to 500
CODE	mL / min [N <sub>2</sub> ]
07	0 to 1
08	0 to 2
09	0 to 5
10	0 to 10
GFC 37 MEDIUM FLOW MASS FLOW CONTROLLER	
11	0 to 15
30	0 to 20
31	0 to 30
32	0 to 40
33	0 to 50
GFC 47 /57 /67 /77 HIGH FLOW MASS FLOW CONTROLLER	
40	0 to 60
41	0 to 80
42	0 to 100
50	0 to 200
60	0 to 500
70	0 to 1000

**TABLE 24 - MAXIMUM PRESSURE DROP FOR GFC**

MODEL	FLOW RATE [liters/min]	MAXIMUM PRESSURE DROP		
		[mm H <sub>2</sub> O]	[psid]	[mbar]
GFC 17	up to 10	720	1.06	75
	15	2630	3.87	266
	20	1360	2.00	138
GFC 37	30	2380	3.50	241
	40	3740	5.50	379
	50	5440	8.00	551
GFC 47	60	7480	11.00	758
	100	12850	18.89	1302
GFC 57	200	7031	10.00	690
GFC 67	500	8437	12.00	827
GFC 77	1000	10547	15.00	1034

### GFC 57, 67 and 77 Series Aluminum and Stainless Mass Flow Controllers

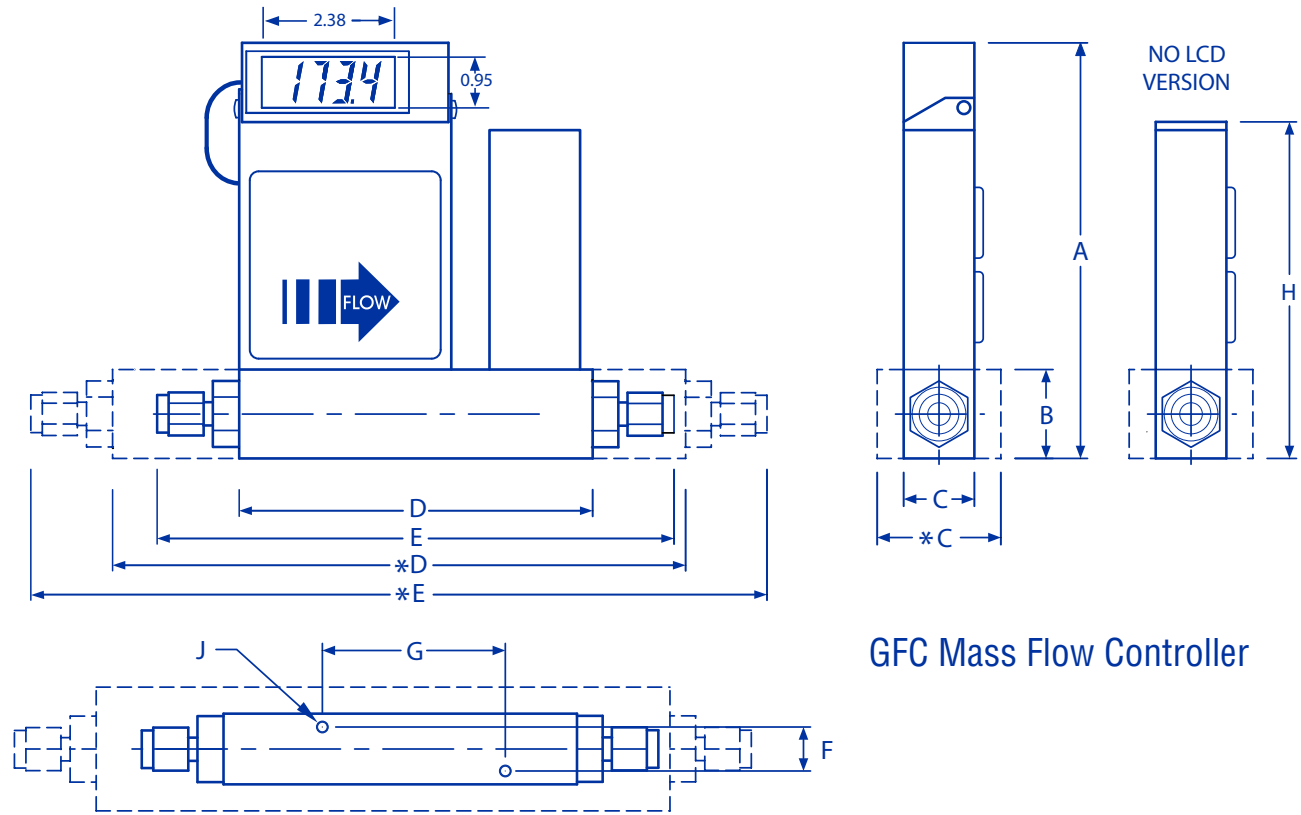

**TABLE 25 - ACCESSORIES FOR GFC**

#### POWER SUPPLY - BATTERY PACK - CABLES

PS-GFC-110NA-2	Power Supply, 110 V/12 Vdc /North America
PS-GFC-110NA-4	Power Supply, 110 V/24 Vdc /North America
PS-GFC-230EU-2	Power Supply, 220 V/12 Vdc /Europe
PS-GFC-230EU-4	Power Supply, 220 V/24 Vdc /Europe
PS-GFC-240UK-2	Power Supply 240 V/12 Vdc /United Kingdom
PS-GFC-240UK-4	Power Supply 240 V/24 Vdc /United Kingdom
PS-GFC-240AU-2	Power Supply 240 V/12 Vdc /Australia
PS-GFC-240AU-4	Power Supply 240 V/24 Vdc /Australia
CBL-DGS	Cable, Shielded 15-pin D-connector /end terminated
17/3RC	Remote Cable, 3 feet long
17/R	Remote LCD readout with 3 feet long cable

**For Totalizer Input/Output Flow Monitor/ Controller options see page 55.**



GFC Mass Flow Controller

TABLE 26 - DIMENSION FOR GFC

MODEL	CONNECTION COMPRESSION FITTING (except model GFC 77)	DIMENSION (INCH)								
		LCD VERSION							NO LCD	MOUNTING HOLE
		A	B	C/*C	D/*D	E/*E	F	G		
GFC 17	1/4" Tube O Diameter	5.72	1.00	1.00	4.27	6.29	0.69	2.69	4.61	6-32
				*C	*D	*E				
GFC 37	1/4" Tube O Diameter	6.10	1.37	1.25	5.19	7.21	0.69	2.69	4.99	6-32
GFC 47	3/8" Tube O Diameter	6.10	1.37	1.25	5.19	7.33	0.69	2.69	4.99	6-32
GFC 57	3/8" Tube O Diameter	6.73	2.00	1.75	10.2	12.3	1.39	4.69	5.62	10-24
GFC 67	1/2" Tube O Diameter	7.55	3.00	3.00	10.24	12.4	2.5	6.80	6.53	1/4-20
GFC 77	3/4" NPT Female	8.66	4.00	4.00	10.5	—	3.0	6.80	7.55	1/4-20

For Specific Flow Ranges Contact Aalborg Customer Service Department.

GFC	MODEL	
MAX. FLOW (N <sub>2</sub> )		
17	10 L/min	
37	50 L/min	
47	100 L/min	
57	200 L/min	
67	500 L/min	
77	1000 L/min	
MATERIAL		
A	Aluminum	
S	Stainless Steel	
SEALS		
V	Viton®	
B	Buna®	
E	EPR	
T	PTFE/ Kalrez®	
FITTINGS		
A	1/4" Compression	GFC 17, 37
B	1/8" Compression	GFC 17
C	1/4" VCR®	GFC 17, 37
D	3/8" Compression	GFC 17, 37, 47, 57
E	1/2" Compression	GFC 67
F	3/4" FNPT	GFC 77
G	3/4" Compression	GFC 77
H	6mm Compression	GFC 17, 37
DISPLAY		
N	No display	
L	LCD readout	
POWER		
6	Universal +12 Vdc to 26 Vdc	GFC 17, 37 and 47
2	12 Vdc	GFC 57, 67 and 77
4	24 Vdc	GFC 57, 67 and 77
INPUT/OUTPUT SIGNAL		
A	Local 0-5 Vdc	
B	Local 4-20 mA	
C	0-5Vdc/0-5Vdc	
D	0-5Vdc/4-20mA	
E	4-20mA/4-20mA	
F	4-20mA/0-5Vdc	
DIGITAL INTERFACE		
O	None	

GFC	17	S	—	V	A	L	2	—	C	O
-----	----	---	---	---	---	---	---	---	---	---

**EXAMPLE: GFC17S-VAL2-CO 10 L/min [N<sub>2</sub>] 20 psig**

***SPECIFY: FLOW RANGE, GAS and PRESSURE*** \*n.a. = not applicable.

GFC17 stainless steel, Viton® seals, 1/4" compression fittings with display, 12Vdc, 0-5 Vdc. Out put signal, No digital interface