

DIAMOND POINT PRINCIPLE OF OPERATION

Apiezo-electric crystal is used to force a blade to oscillate at its fundamental frequency (natural resonance). When the blades come into contact with the process medium the natural frequency of oscillation is damped; the electronics sense the change in frequency which causes the unit to switch. The operating principle is the same for all vibrating probe level switches.

The choice of different electronic outputs allow the user to switch a load on/off or to interface directly with a computer. The units can be programmed to sense high- or low-level and failsafe high or low, with adjustable sensitivity to eliminate false switching. The switch is only sensitive at the tip so minimising the effect of build-up on tank walls.

DIAMOND POINT TECHNOLOGY ADVANTAGES

The vibration technology at the heart of the DP Series level switches offers many unique advantages over alternative level sensing technologies:

- ◆ No moving parts
- ◆ No maintenance required
- ◆ Unaffected by environmental changes e.g. temperature, pressure, humidity
- ◆ Unaffected by material changes, dielectric etc.
- ◆ Unaffected by dust clouds and agitation
- ◆ No calibration required
- ◆ Unique self cleaning probe
- ◆ Stainless steel corrosive resistant
- ◆ Minimum bulk density 10 grams / ltr.

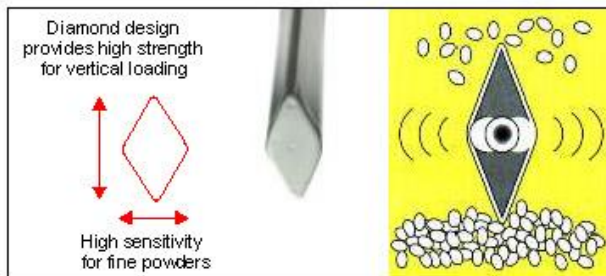

DISADVANTAGES OF TWIN FORK AND ROD DESIGN

Hycontrol's diamond point design is unique in both shape and construction. This shape provides a self-cleaning effect that prevents the build-up of falling media along the sensing blade, while in a horizontal position it will sense a rising surface. The cleverly engineered web support design gives the probe more strength and stability, thus providing a more accurate reading and preventing premature failure.

- ◆ Conventional twin forks can become 'bridged' which can cause false alarms
- ◆ Twin fork designs require more maintenance and reduced sensitivity
- ◆ More chance of material build-up on larger round surface, cause false switching
- ◆ Round probes are more likely to 'carve out' a hollow place to vibrate inside the material
- ◆ Can false-switch when covered with product
- ◆ Weaker design compared to unique patented Knife Diamond profile. This diamond design in the vertical loading plane is up to 5 times stronger with the reinforced web support (*see above picture*)

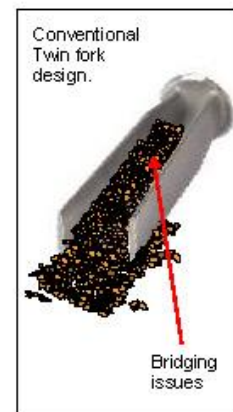

SWITCHES FOR SOLIDS APPLICATIONS

The design of a vibrating level switch for solids must be fundamentally different to the design described for liquids. If two large parallel blades were used on powders or solids it would be too easy for product to build-up and become lodged between the blades causing the oscillations of the switch to stop regardless of product level.

For solids applications on products ranging from cornflakes to coal, it is preferable to have only one blade in contact with the product. This eliminates the potential for bridging between the forks and ensures that the switch does not give false alarms.

DP120, 130, 140 & 150 DIAMOND PROBE

The design of the Diamond Probe produces the most rugged but sensitive switch for solids applications. The hollow diamond shaped blade houses the second vibrating rod inside. The blade is very strong in the vertical direction to withstand falling solids and to ensure that product does not build upon it, but retains its flexibility and sensitivity in the horizontal mode enabling it to sense products with very low bulk densities.



Diamond Point DP120, 130, 140 & 150

DP600

The DP600 series uses the piezo element to excite an 85mm long stainless steel rod to its resonant frequency of 460Hz. When the material covers the rod it stops the vibration.

The DP600 is suitable for use on pellets and granules. It will detect the presence of solid materials with bulk density greater than 90 grams per litre. It is not suitable for sticky materials or materials that tend to hang-up.



DP600 Series

DP660

The DP660 model is a low-cost OEM product designed specifically to be supplied in volume and fitted into other companies products. It has a 1 inch NPT or DIN 2999 G1 process connection and a PNP or relay output. This is also suitable for products with bulk density of 90 grams per litre or greater.



660 Series Low Cost for OEM

TYPICAL SOLIDS APPLICATIONS

- ◆ Grain
- ◆ Tea (leaf)
- ◆ Salt
- ◆ Flour
- ◆ Spices
- ◆ Soda
- ◆ Animal food
- ◆ Cornflakes
- ◆ Glass (ground)
- ◆ Granular plastics
- ◆ Powdered clay
- ◆ Polystyrene
- ◆ Gravel
- ◆ Filler materials
- ◆ Cement
- ◆ Lime
- ◆ Powdered milk
- ◆ Frozen chips
- ◆ Beans
- ◆ Sugar
- ◆ Sweets
- ◆ Coffee beans
- ◆ Peanuts
- ◆ Tobacco
- ◆ Pellets
- ◆ Carbon black
- ◆ Chemicals
- ◆ Foundry sand
- ◆ Wood shavings
- ◆ Chalk
- ◆ Styrofoam
- ◆ Cellulose

SEDIMENT DETECTION

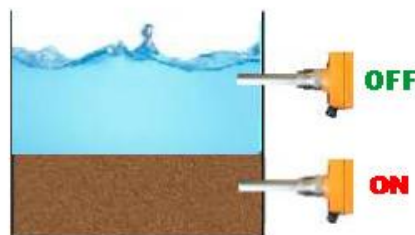

Hycontrol's vibrating probes are designed for the detection of all kinds of bulk solids; powdered, grained or in a granular state. Its robust design and its high sensitivity makes it perfect for a wide range of applications from heavy materials in rough environments down to the detection of light materials and powders. This includes detecting solids underneath liquids using a special model option for **SEDIMENT**. Typical applications include salt saturators for detecting salt under water and sand settlement from production processes.

LEVEL SWITCHES DP120/DP130/DP140/DP150

The Diamond Point Level Switch is designed specifically for use with dry products ranging from stone aggregates and heavy materials such as cement, to very low density materials like comflakes and fine powder or flour.

Its unique principle of operation and shape ensures that it is self-cleaning and because it is only sensitive at its tip it is not influenced by build-up on the silo walls.

DIAMOND POINT: SINGLE BLADE

The single blade design, with its reinforced diamond shaped vibrating blade, prevents material build-up or bridging which are typical problems associated with the dual blade 'tuning fork' design.

As it is very sensitive in the lateral mode the level switch can be used for extremely light materials with densities as low as 20 grams per litre.

The strong stainless steel construction gives the Diamond Point level switch strength in the vertical direction for use with heavy materials such as cement or aggregates.

Material build-up on the container wall has no influence on the function of the Diamond Point level switch as only the tip of the vibrating blade is sensitive and not the base.

The electronic circuit of the Diamond Point level switch includes indication of power failure. Fail safe high or low is selectable.



DIAMOND POINT: DP120

The standard model DP120 has an insertion length of approx. 173 mm and can be mounted to the container from top or from side for both high or low level detection. Connection to the container or vessel is made via thread 1 1/2" BSP, NPT or DIN.



WELDED EXTENSION: DP130

If the application requires ATEX or a longer insertion length, this model offers the possibility to adapt the insertion length exactly to the length required by means of a pipe which is welded between the vibrating probe and the 1 1/2" mounting socket. Maximum insertion length for DP130 is 2.0 metres. The DP130 is suitable for top mounting.



THREADED EXTENSION: DP140

The DP140 provides the flexibility of different insertion lengths up to 4.0 metres. The extension is performed by a 1" pipe with threads on both ends screwed between the vibrating probe and the 1 1/2" mounting socket. As no special equipment is necessary for making the extension it is possible for the customer to obtain and mount the extension tube at the site which helps to reduce spares and save costs for transportation. The DP140 is suitable for top mounting but not for ATEX applications.



FLEXIBLE CABLE EXTENSION: DP150

The DP150 can be supplied with up to 20 metres of a polyurethane sheathed, steel rope reinforced cable. The DP150 is for top mounting only. The connection to the container is made by a 1 1/2" DIN or NPT thread. The DP150 has the advantage of offering very long insertion lengths but also provides easy transport as it can be shipped in very compact boxes in comparison to the extension tube models DP130 and DP140. The DP150 can be used for the detection of solids or for the detection of sediment below the liquid level.



LEVEL SWITCHES DP600/DP630/DP650/DP660

The DP600 series has a single solid stainless steel rod which is vibrated by the piezo-electric element. Due to its small size it is ideal for use in small hoppers containing granular materials or pellets, like plastics, food or grain. It should be noted that the circular construction of the DP600 means it is not as sensitive to light materials as other DP probes. The 600 series should only be used on materials which have a bulk density greater than 90 grams per litre.

PRINCIPLE OF OPERATION FOR ALL VIBRATING PROBE LEVEL SWITCHES

A piezo-electric crystal is used to force a blade to oscillate at its fundamental frequency (natural resonance). When the blades come into contact with the process medium the natural frequency of oscillation is damped; the electronics sense the change in frequency which causes the unit to switch. The operating principle is the same for all vibrating probe level switches.

The choice of different electronic outputs allow the user to switch a load on/off or to interface directly with a computer. The units can be programmed to sense high- or low-level and failsafe high or low, with adjustable sensitivity to eliminate false switching. The switch is only sensitive at the tip so minimising the effect of build-up on tank walls.

ADVANTAGES OF VIBRATING PROBES

- ◆ No mechanical moving parts to wear
- ◆ No maintenance required
- ◆ Simple to install - no adjustments required
- ◆ Unaffected by environmental changes
- ◆ Unaffected by dust clouds and agitation
- ◆ Maximum versatility

STANDARD LENGTH: DP600

The standard model DP600 has an insertion length of approx. 173 mm and can be mounted to the container from top or from side for both high or low level detection. Connection to the container or vessel is made via thread 1" BSP, NPT or DIN.

PIPE EXTENSION: DP630

If the application requires longer insertion length, this model offers the possibility to adapt the insertion length exactly to the length required by means of a pipe which is welded between the vibrating probe and the 1½" mounting socket. Maximum insertion length for DP630 is 2.0 metres. The DP630 is suitable for top mounting.

THREADED EXTENSION: DP650

The DP650 can be supplied with up to 4 metres of a polyurethane sheathed, steel rope reinforced cable. The DP650 is for top mounting only. The connection to the container is made by a 1" DIN or NPT thread. The DP650 has the advantage of offering very long insertion lengths but also provides easy transport as it can be shipped in very compact boxes in comparison to the extension tube models DP630. The DP650 can be used for the detection of solids or for the detection of sediment below the liquid level.

FLEXIBLE CABLE EXTENSION: DP660

The DP660 is for OEM applications and provides the best technology for the lowest price. The DP660 can be mounted on the top or on the side of the container for both high or low detection. Connection to the container or vessel is made via thread 1" BSPT, DIN 2999 or 1" NPT.



DP600



DP630



DP650



DP660

SPECIFICATION

Enclosure	DP120	DP130	DP140	DP150
	Die Cast Aluminium	Die Cast Aluminium	Die Cast Aluminium	Die Cast Aluminium
	IP66/7	IP66/7	IP66/7	IP66/7
Electrical Connection	PG13.5 (Option for 2)	PG13.5 (Option for 2)	PG13.5 (Option for 2)	PG13.5 (Option for 2)
Material Wetted Parts	Stainless Steel 1.4301	Stainless Steel 1.4301	Stainless Steel 1.4301	Stainless Steel 1.4301
Process Connection	1½ DIN 2999 or 1½ NPT	1½ DIN 2999 or 1½ NPT	1½ DIN 2999 or 1½ NPT	1½ DIN 2999 or 1½ NPT
Max. Vertical Load at end of Blade	1000N	1000N	1000N	1000N
Max. System Pressure	10 bar	10 bar	10 bar	10 bar
Max. External Length	173mm	2m	4m	20m
SHT Option.	250°C	250°C	250°C	NA
System Temperature	-20°C to +80°C	-20°C to +80°C	-20°C to +80°C	-20°C to +80°C
Power Supply	20 – 250V AC or DC	20 – 250V AC or DC	20 – 250V AC or DC	20 – 250V AC or DC
Power Consumption	3 VA	3VA	3VA	3VA
Output	Relay SPDT or DPDT 250 V AC 5A	Relay SPDT or DPDT 250 V AC 5A	Relay SPDT or DPDT 250 V AC 5A	Relay SPDT or DPDT 250 V AC 5A
PNP or NPN	8/16mA	8/16mA	8/16mA	8/16mA
Indication (internal)	Relay - Red Power - Yellow	Relay - Red Power - Yellow	Relay - Red Power - Yellow	Relay - Red Power - Yellow
Switch Delay	1 – 5 seconds.	1 – 5 seconds.	1 – 5 seconds.	1 – 5 seconds.
Min. Product Density	10 grams per litre (special)	10 grams per litre (special)	10 grams per litre (special)	10 grams per litre (special)
Ambient Temp. Range	-20°C to +60°C	-20°C to +60°C	-20°C to +60°C	-20°C to +60°C

Approvals

CE Approval	EMC 890/336/EEC	EMC 890/336/EEC	EMC 890/336/EEC	EMC 890/336/EEC
Low Voltage	73/23/EEC	73/23/EEC	73/23/EEC	73/23/EEC
ATEX Gas	Group II 1G Ex ia IIB T4 <small>Group II 1/2D Ex tD A20/21 T95°C</small>	Group II 1G Ex ia IIB T4 <small>Group II 1/2D Ex tD A20/21 T95°C</small>	-	Group II 1G Ex ia IIB T4 <small>Group II 1/2D Ex tD A20/21 T95°C</small>
ATEX Dust	Group 1D Ex ia D20 TX	Group 1D Ex ia D20 TX	-	Group 1D Ex ia D20 TX
Ground Level Test Facility	Optional	Optional	Optional	Optional

The instruments are ATEX classified as follows:

	Equipment Group	Category	Suitable for zones
Vibrating Probe:	II	1 D	20, 21, 22 or non-explosive atmospheres
Enclosure with electronics:	II	2 D	20, 21, 22 or non-explosive atmospheres
Protection is provided according to EN5028-1-1-1:		-	Dust-tight enclosure IP6CX
		-	Limited surface temperature

SPECIFICATION

Enclosure	DP600	DP630	DP650	DP660
	Die Cast Aluminium IP66/7	Die Cast Aluminium IP66/7	Die Cast Aluminium IP66/7	Stainless Steel IP66
Electrical Connection	M16 (Option for 2)	M16 (Option for 2)	M16 (Option for 2)	DIN 43650
Material Wetted Parts	Stainless Steel 1.4301 / AISI 304	Stainless Steel 1.4301 / AISI 304	Stainless Steel 1.4301 / AISI 304	Stainless Steel 1.4301
Process Connection	1"BSPT/ DIN 2999/1"NPT	1"BSPT/ DIN 2999/1"NPT	1"BSPT/ DIN 2999/1"NPT	1"BSPT/ DIN 2999/1"NPT
Max. Vertical Load at end of Blade	80N	80N	80N	80N
Maximum Extension Length.	-	1m	4m	-
Max. System Pressure	10 bar	10 bar	10 bar	10 bar
System Temperature	-20°C to +80°C	-20°C to +80°C	-20°C to +80°C	70°C
Power Supply	20 – 250V AC or DC	20 – 250V AC or DC	20 – 250V AC or DC	24V DC
Power Consumption	2 VA	3VA	3VA	-
Output	Relay SPDT	Relay SPDT	Relay SPDT	Relay SPDT
	250 V AC 5A	250 V AC 5A	250 V AC 5A	50 V 1A
2 Wire	8/16mA	8/16mA	8/16mA	8/16mA
Indication (internal)	Relay - Red	Relay - Red	Relay - Red	Relay - Red
	Power - Yellow	Power - Yellow	Power - Yellow	-
Switch Delay	1 – 5 seconds.	1 – 5 seconds.	1 – 5 seconds.	1 – 5 seconds.
Min. Product Density	90 grams per litre	20 grams per litre	20 grams per litre	90 grams per litre
Ambient Temp. Range	-20°C to +60°C	-20°C to +60°C	-20°C to +60°C	-20°C to +60°C

Approvals

CE Approval	EMC 2004/108/EC	EMC 2004/108/EC	EMC 2004/108/EC	EMC 2004/108/EC
Low Voltage	2006/95/EC	2006/95/EC	2006/95/EC	2006/95/EC
ATEX	Yes	(pending)	(pending)	(pending)

GROUND LEVEL TEST FACILITY

Vibrating switches have the facility to be connected to a test switch or panel mounted at the bottom of the tank or silo, which allows the high level probes to be tested without the need to climb to the top of the silo. The test is designed to be operated before each tank fill starts. A single push of the Ground Level Test (GLT) button on the control panel stops the probe vibrating and tests the probe electronics are working satisfactorily. Any alarms which are connected will also operate during the test to check that they are functioning correctly. The GLT feature has the added benefit of helping to reduce product wastage and avoid the need for costly clean up operations from any overspill incident, as well as improving the overall safety in the working environment.

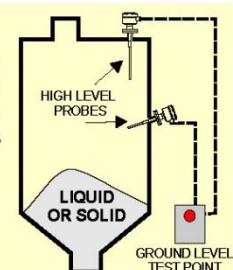

DRAWINGS

DP120

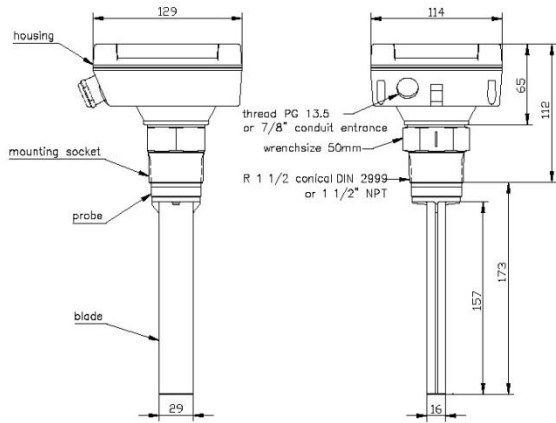

DP130

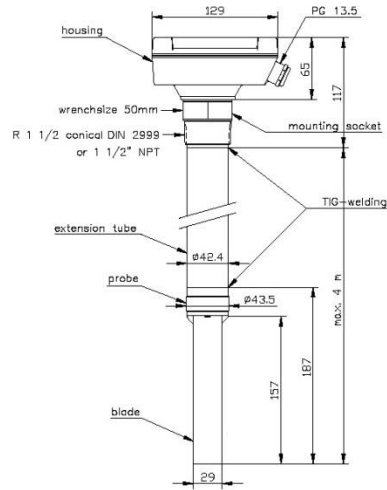

DP140

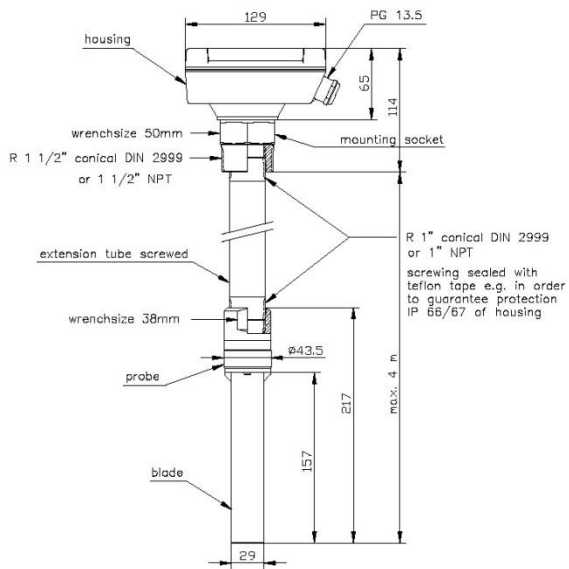

DP150

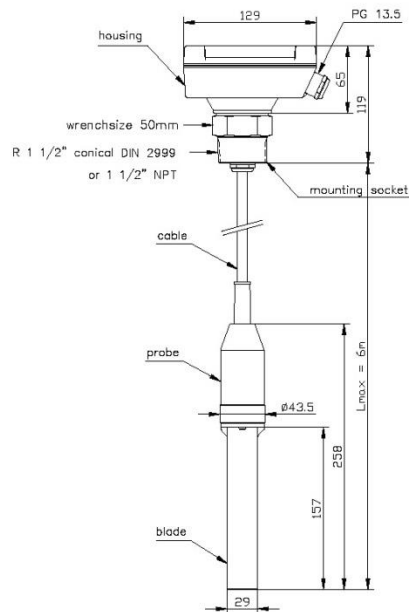

DRAWINGS

DP600

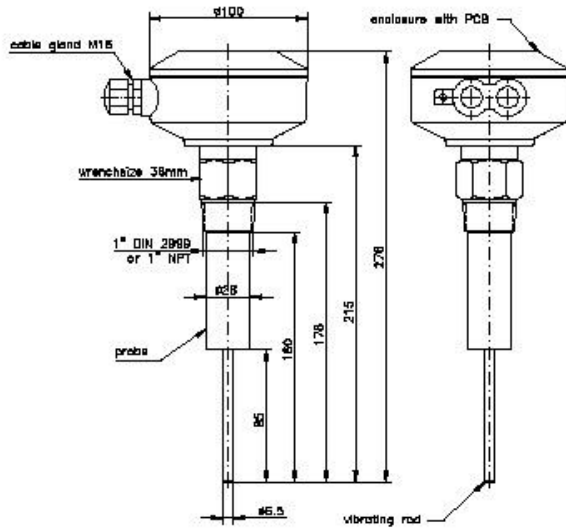

DP630

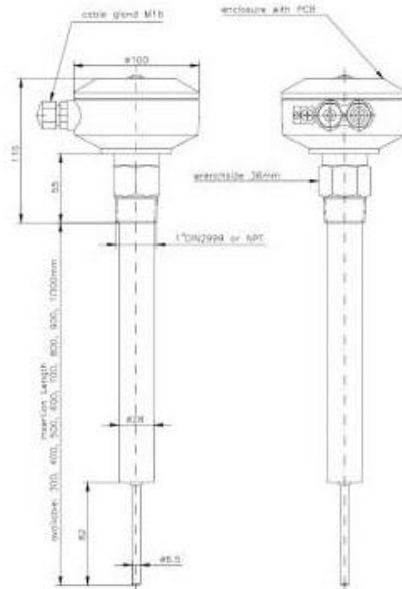

DP650

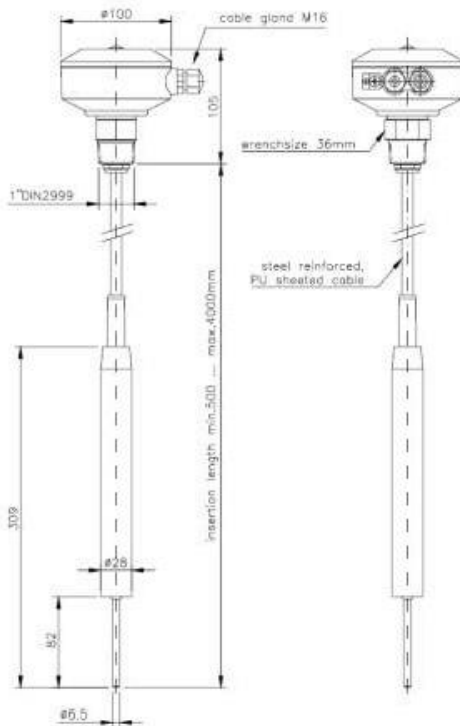

DP660

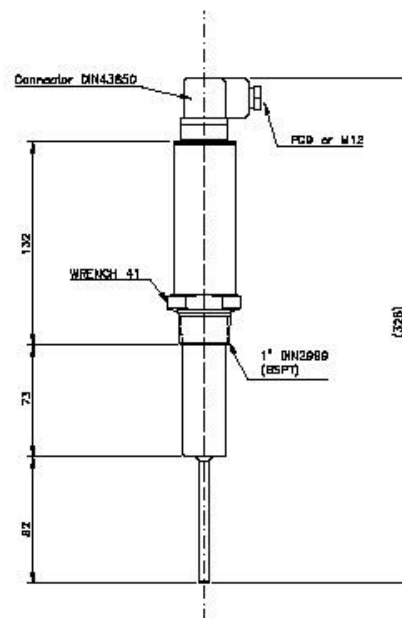

Product Range For Solids :-

- (1) TDR Radar For Solids
- (2) Ultrasonic, 'Through Air'
- (3) 2 Wire Ultrasonic Transmitter
- (4) FMCW 2 Wire Radar
- (5) Continuous 'Servo' Level Indicator
- (6) Capacitance Level Switch
- (7) Vibrating Probe Level Switch
- (8) Rotating Paddle Level switch
- (9) Microwave Level Switch
- (10) Doppler Flow Switch

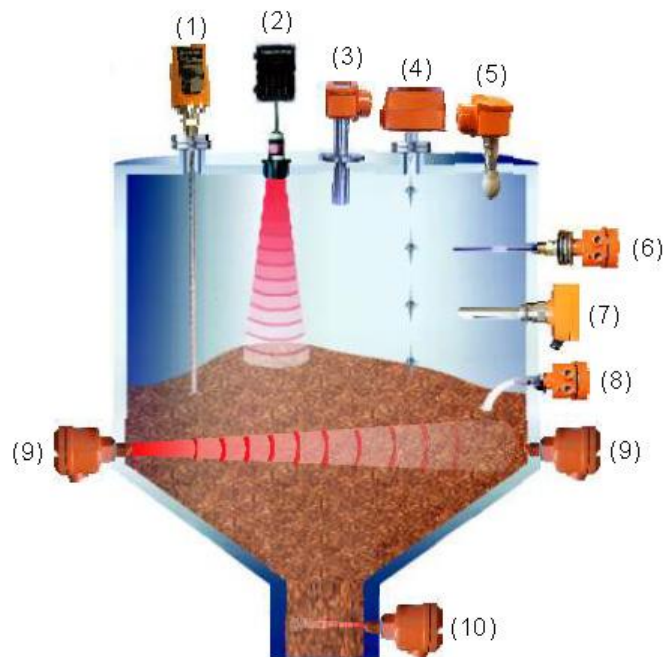

Product Range For Liquids :-

- (1) By-Pass Level Indicator With Radar
- (2) TDR Radar For Liquids
- (3) 2 Wire Ultrasonic Transmitter
- (4) FMCW 'Horn' Radar 2 Wire
- (5) Magnetic Float Switches
- (6) FMCW 2 Wire Radar
- (7) Capacitance Level Switch
- (8) RF Admittance Level Switch
- (9) Side Mounting 316 SS Float Switch
- (10) Tuning Fork Level Switch
- (11) Tuning Fork Level Switch
- (12) Ultrasonics 'Through Wall'
- (13) Mini Magnetic Float Level Switch

